

# Reed Switch Life Characteristics under Different Levels of Capacitive Loading

June 14, 2004

Stephen Day  
VP Engineering  
Coto Technology

## Summary

Life tests were run on four types of Coto Technology reed switches at four different, increasingly capacitive load levels, and three resistive loads. The objective was to determine which type of switch is most resistant to welding under simulated application conditions. The results show that the RI-29 switch offers the best general performance across all loads. Little evidence of welding was found for any switch at any load; most end-of-life failures were due to misses or excessive static contact resistance.

## Introduction

Coto Technology has conducted welding tests on several different switch types manufactured at its facility in Heerlen, the Netherlands. The objective was to determine which switch type offers optimal resistance to welding when switching reactive loads. The switch types tested were the RI-27, RI-29, RI-60 and RI-X. The latter was an experimental switch, which is not in production. The AT range of all the switches used fell between 14 and 19 AT.

## Experimental Results

### Test Setup

The reed switches were molded into type 9000 SIP relays with 5V, 500-ohm coils. They were tested with four different switch loads, numbered 1, 3, 5 and 7, as outlined in the diagram and table shown below. Sixteen switches of each type were tested with each load, and were cycled to 100 million operations or 50% failure, whichever occurred first.

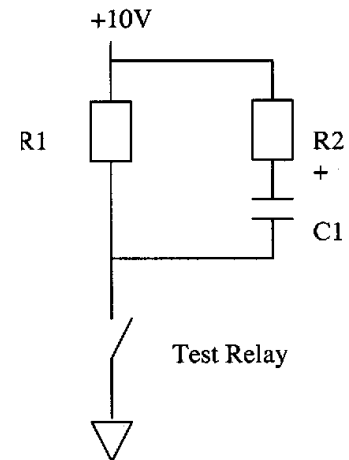

## Primary Test Loads

Load	I (mA)	I peak (mA) 500 uS	R1 ohm	R2 ohm	C1 (uF)
1	4	4	2490	Open	Open
3	10	100	1000	100	5
5	40	500	249	20	25
7	100	1000	100	10	50

## Supplementary Test Loads

RI-27 and RI-29 switches were also tested using three purely resistive loads; 12V 4mA and 20V 500 mA, plus another data set generated at 80V. The 80V load was designed to simulate an initial inrush current peaking at 0.7A and stabilizing at 0.1 mA.

## Failure recording

Failures were recorded as sticks (failure to open when the relay coil is de-energized) or misses (failure to close when the relay is energized.) These failure events can be further classified as “hard” or “soft” depending on how long they last

## Failure Criteria

### ***Soft Miss (SM)***

Contact resistance  $\geq 1$  ohm,  $\geq 40$  milliseconds but less than 45.5 milliseconds after coil energization. Made on every test cycle.

### ***Hard Miss (HM)***

Contact resistance  $\geq 1$  ohm at 500 milliseconds. Test initiated after a soft miss is recorded.

### ***Soft stick (SS)***

Contact resistance  $\leq 1000$  ohm,  $\geq 40$  milliseconds but less than 45.5 milliseconds after coil is de-energized. Made on every test cycle.

### ***Hard Stick (HS)***

Contact resistance  $\leq 1000$  ohm at 500 milliseconds after coil de-energization. Test initiated after a soft stick is recorded.

### ***Logpoint static contact resistance (SCR)***

Static contact resistance measured 10 milliseconds after cold contact closure, using a 50 mA source. Made every n cycles, where n = the logpoint interval and is typically 10,000 or 100,000 cycles. Failure criterion was a recorded value  $\geq 200$  milliohms.

## Results

The following table shows, for the primary test loads, the number of recorded failure events and the total number of relays failing for any reason. Since multiple types of failure can occur between log points, the sum of individual events can exceed the total number of relays failing. A relay failure was counted on the first failure event between log points.

Switch type	Load #	Failure Event Count					Total # relay failures
		SM #	HM #	SS #	HS #	SCR #	
RI-27	7	0	1	4	1	10	16
RI-29	7	0	0	0	0	0	0
RI-60	7	2	1	0	0	14	15

RI-27	5	3	4	0	0	6	10
RI-29	5	2	3	0	1	2	5
RI-60	5	10	8	0	0	8	16

RI-27	3	0	0	0	0	1	1
RI-29	3	3	7	0	0	1	11
RI-60	3	14	11	0	1	1	27

RI-27	1	0	0	2	7	1	10
RI-29	1	2	6	0	2	0	10
RI-60	1	4	1	0	2	10	17

## Weibull Analysis

The following three pages show Weibull plots for each switch across the four primary loads. These are “true” Weibull plots, in that they show the best fit to a two-parameter Weibull distribution. The y-axis of each plot represents unreliability, which is closely related to the cumulative percentage of the population of switches failing. The x-axis of the plots show the number of relay operations in millions of cycles. Weibull statistics allow simple calculation of the mean cycles to failure (MCBF), and the predicted number of cycles before any given percentage failure. Though useful for comparison purposes, the MCBF failure rate would never be allowable in typical relay applications. Therefore the Weibull plots were also used to compute the 1% failure rates, and these estimates are shown later in this report.

**Graph Key:** (example) L1RI27 Weibull plot for Load 1, RI-27 switch

(Note that a bug in Adobe Acrobat may prevent some data containing math symbols from being printed at the base of the Weibull plots. This data is not needed for interpretation of the plots.)

RI-27 life vs. load

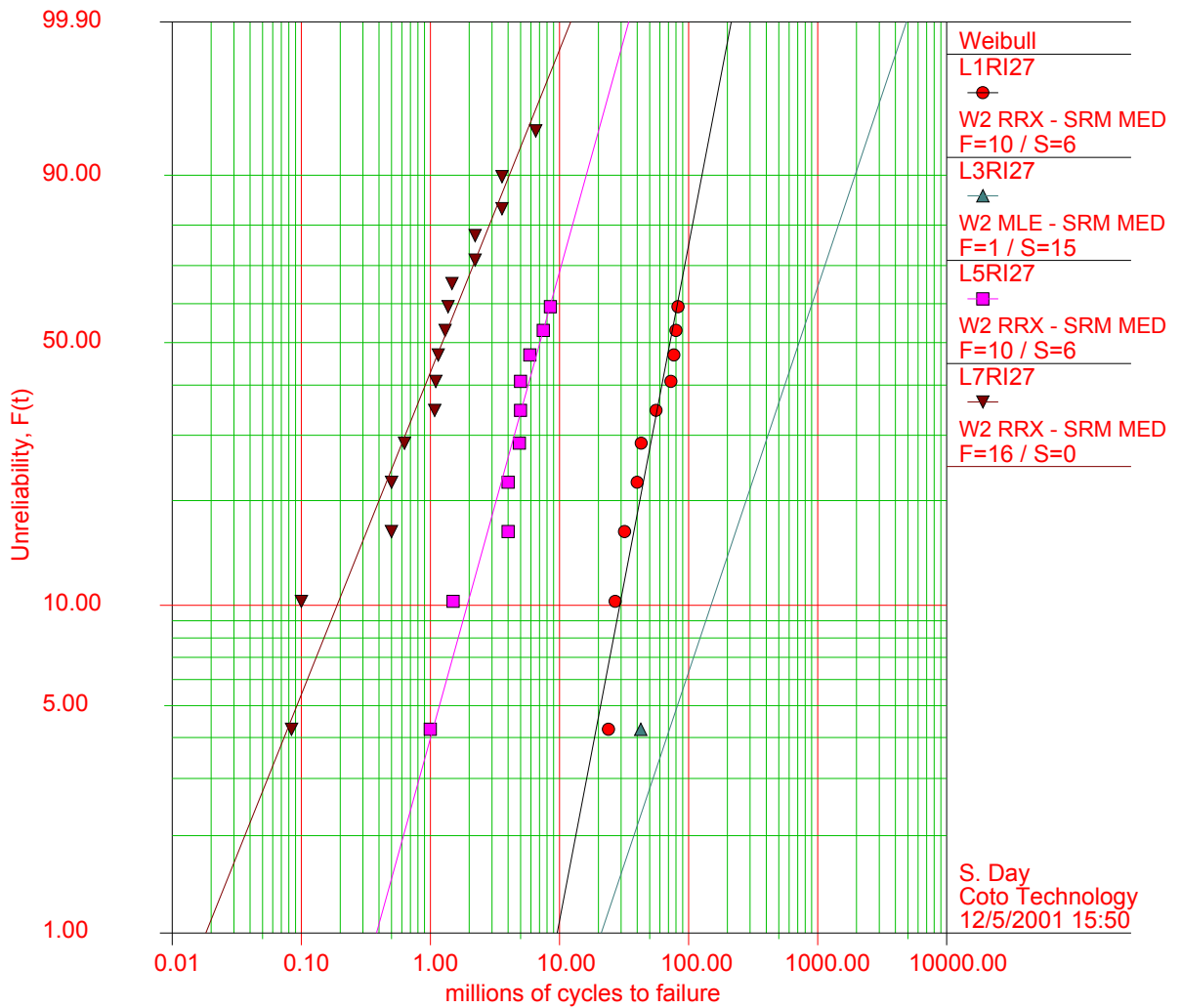

$\beta_1=2.1043, \eta_1=85.6026, \rho=0.9577$   
 $\beta_2=1.2000, \eta_2=974.2181$   
 $\beta_3=1.4517, \eta_3=9.1174, \rho=0.9658$   
 $\beta_4=1.0033, \eta_4=1.7860, \rho=0.9766$

RI-29 life vs. load

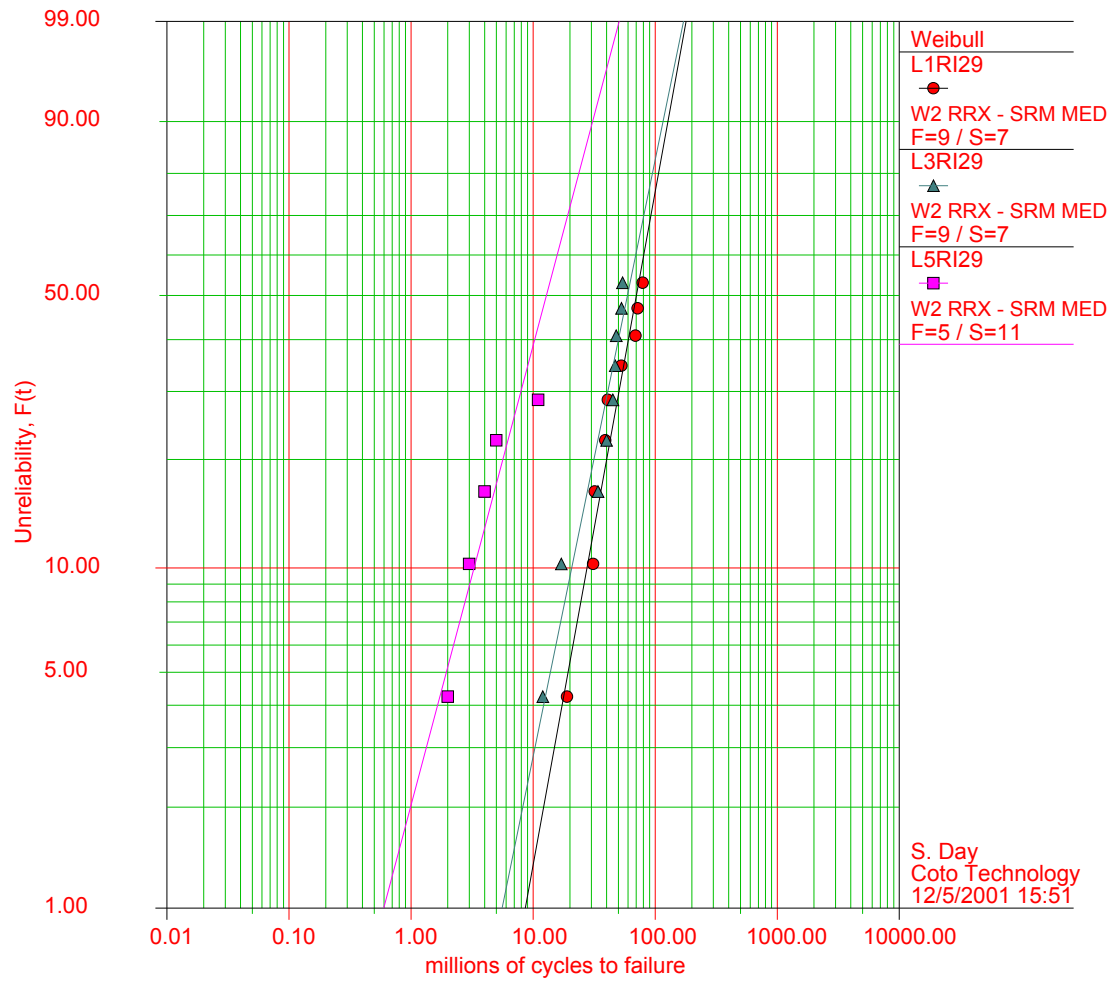

$\beta_1=2.0208, \eta_1=84.1903, \rho=0.9727$   
 $\beta_2=1.7900, \eta_2=72.8668, \rho=0.9644$   
 $\beta_3=1.3796, \eta_3=16.7779, \rho=0.9194$

### RI-60 life vs. load

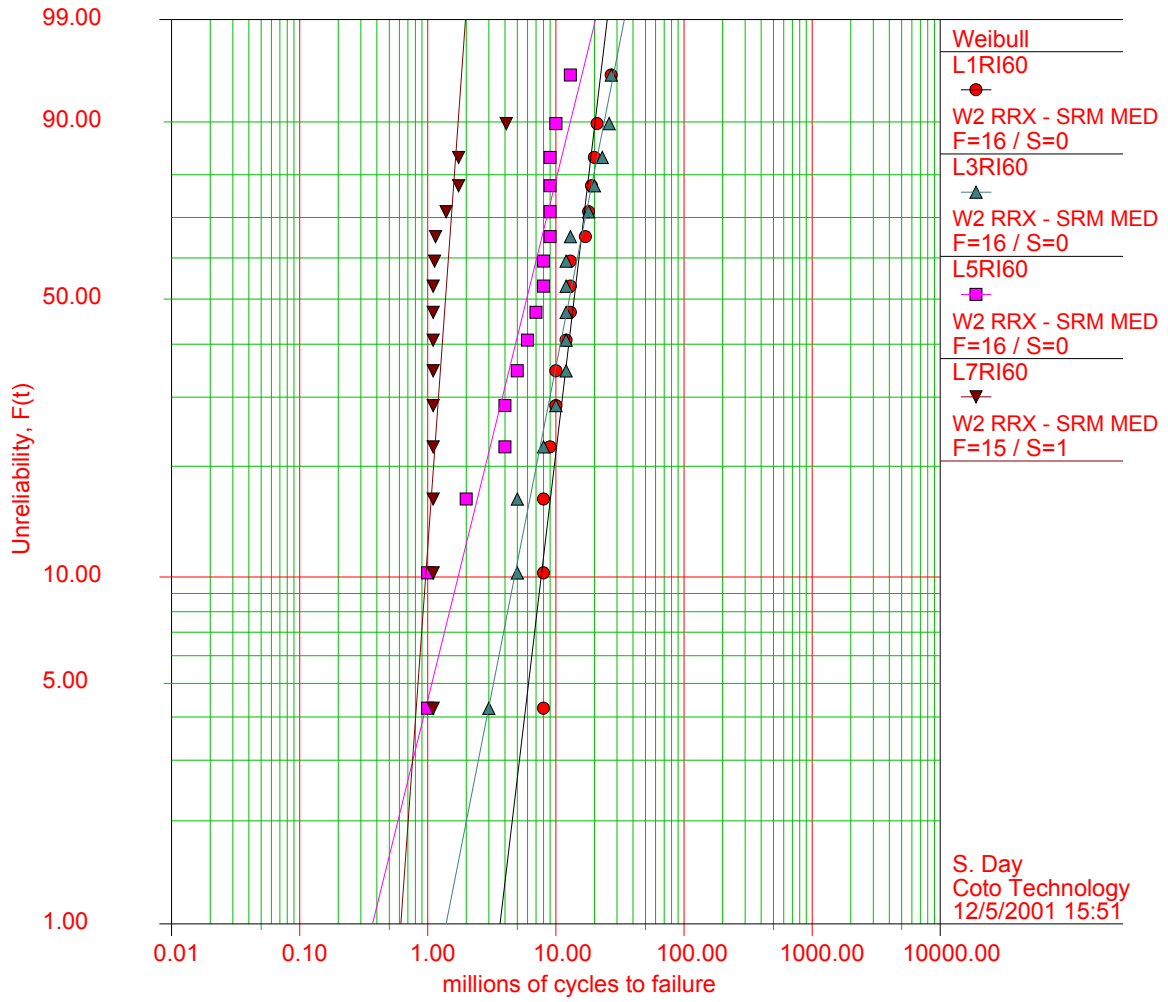

$\beta_1=3.1830, \eta_1=15.5814, \rho=0.9392$   
 $\beta_2=1.9118, \eta_2=15.4300, \rho=0.9797$   
 $\beta_3=1.5283, \eta_3=7.5186, \rho=0.9565$   
 $\beta_4=5.2789, \eta_4=1.4739, \rho=0.5884$

The following table shows the predicted mean cycles to failure for each switch type at each load. The predictions are based on a 2-parameter Weibull distribution fitted to the failure data.

Load Class	Load Type	RI-27	RI-29	RI-60
Primary	Load 1	75.8	74.6	13.9
"	Load 3	>100	64.8	13.7
"	Load 5	8.3	104.2	6.8
"	Load 7	1.8	>100	2.4
Supplementary	12V 4 mA	300	82	-
"	80V 0.1mA/0.7A	10	140	-
"	20V 500 mA	0.35	80	-

Note 1 RI-29 Load 3 data was calculated with a 3-parameter Weibull distribution, since the curved two-parameter Weibull plot indicated a "safe period" of about one million cycles before any failures occurred.

This table shows the expected number of cycles before 1% failure of each switch type. Note that a prediction for the RI-29 switch at Load 7 cannot be made, since no failures were recorded before test suspension at 100 million cycles. (See discussion below)

Load Class	Load Type	RI-27	RI-29	RI-60
Primary	Load 1	9.6	8.6	3.7
"	Load 3	0.59	5.6	1.4
"	Load 5	0.38	1.9	0.37
"	Load 7	0.018	N/A	0.62
Supplementary	12V 4 mA	52	20	-
"	80V 0.1mA/0.7A	2.6	52	-
"	20V 500 mA	0.1	10	-

The predominant failure modes are shown in the following table.

Load Class	Load Type	RI-27	RI-29	RI-60
Primary	Load 1	Stick	Miss	SCR
"	Load 3	SCR	Miss	Miss
"	Load 5	SCR	Miss	SCR/miss
"	Load 7	SCR	None	SCR
Supplementary	12V 4 mA	SCR	SCR	-
"	80V 0.1mA/0.7A	Stick	Stick	-
"	20V 500 mA	Stick	Stick	-

### **Confidence Limits for MCBF data**

The following charts show the predicted MCBF for each switch at each primary test load, including the upper and lower two-side 90% confidence limits. RI-27 Load 3 and RI-29 Load 7 are omitted because their predicted MCBF is an undefined number above 100 million cycles.



### Load 1 MCBF 90% confidence limits

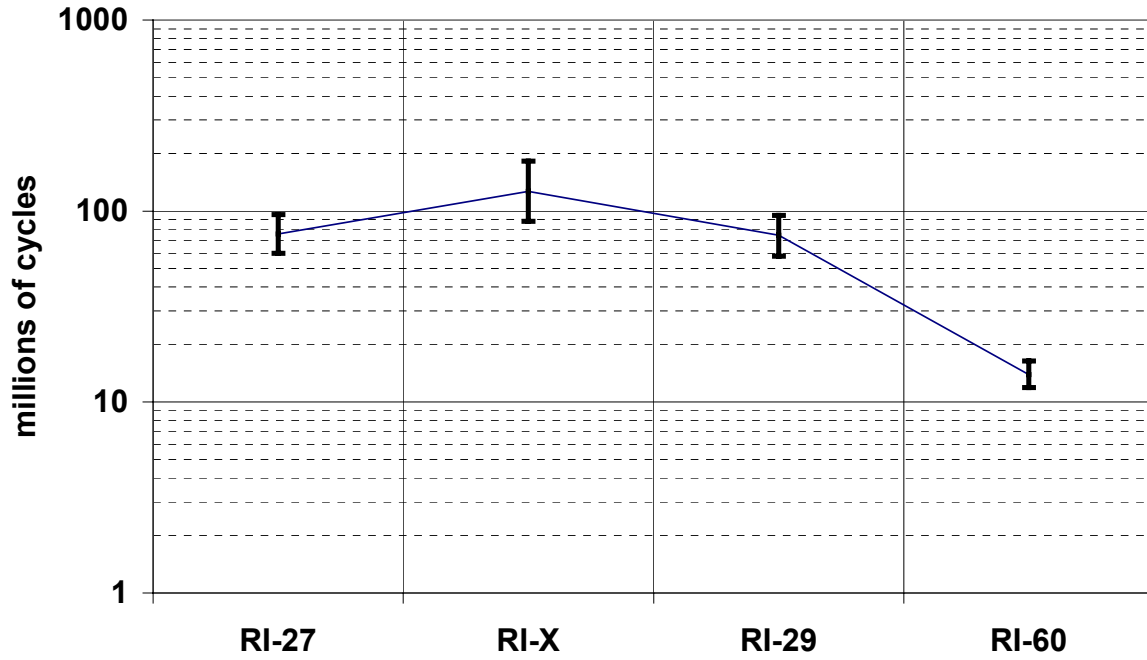

### Load 3 MCBF 90% confidence limits

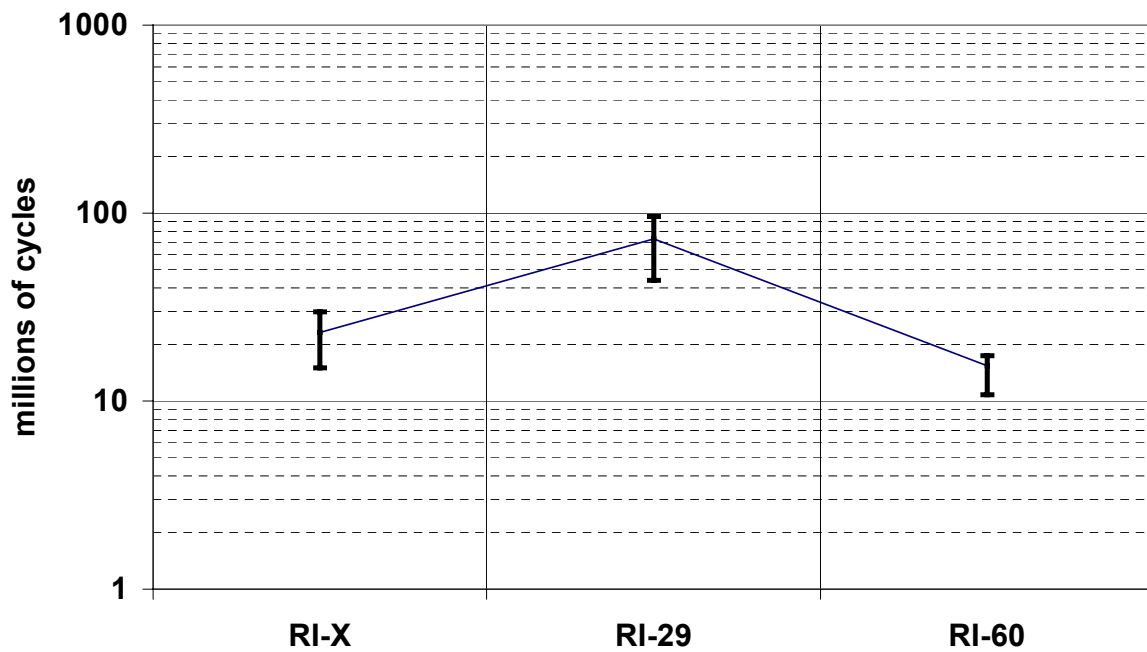

### Load 5 MCBF 90% confidence limits

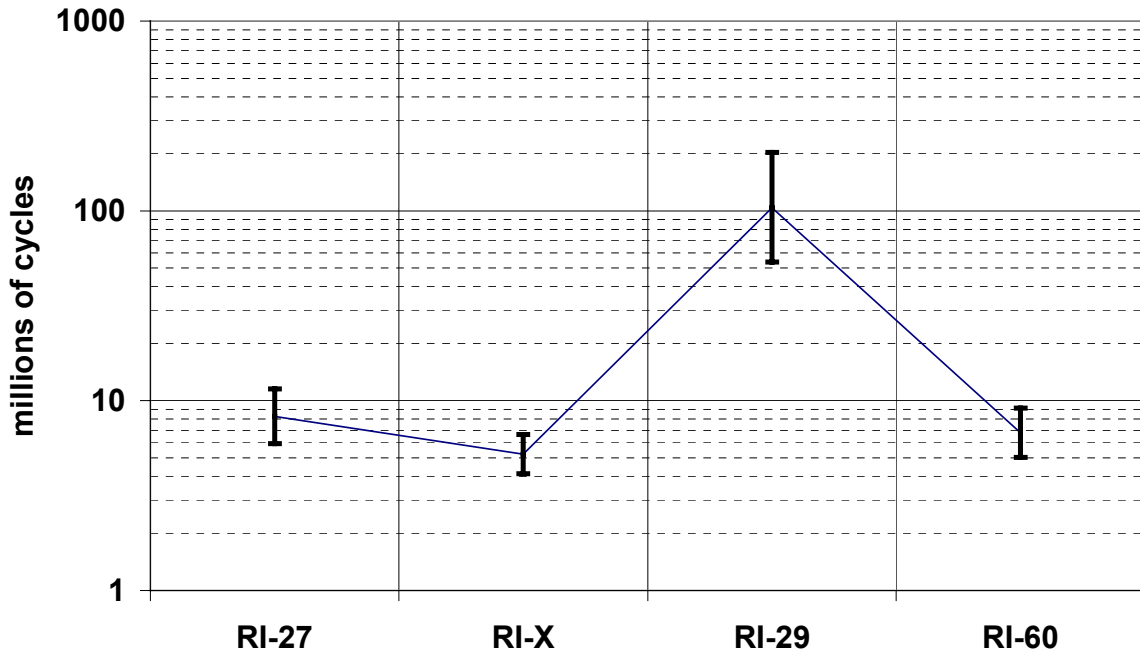

### Load 7 MCBF 90% confidence limits

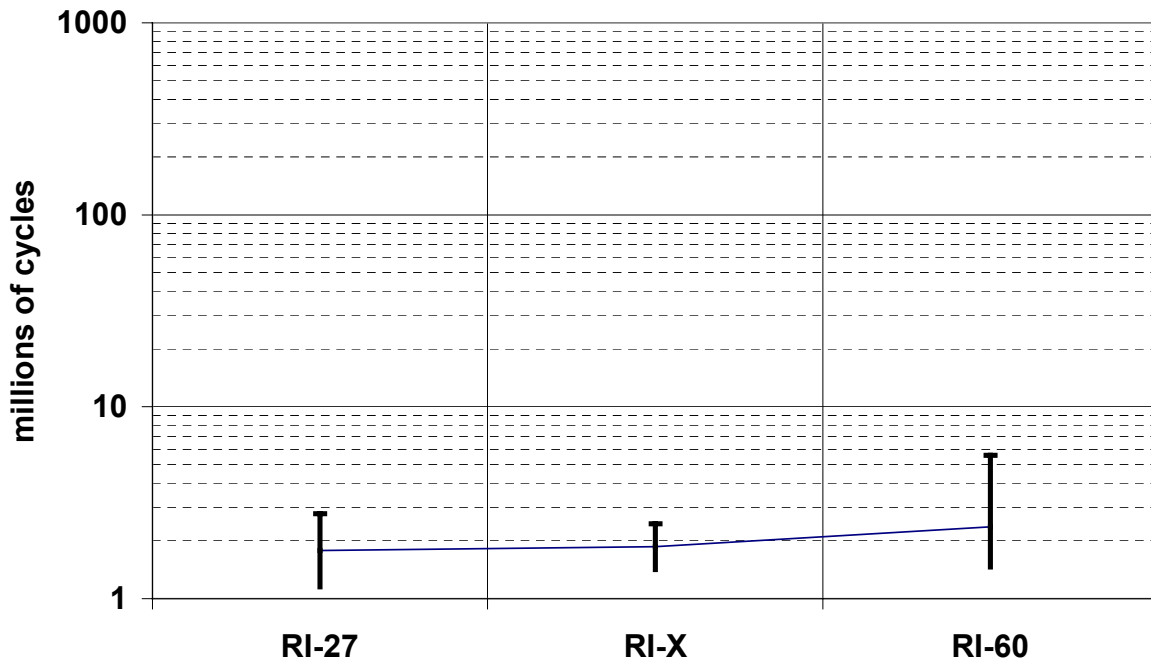

## Discussion and Conclusions

Though these tests were originally designed to understand and predict welding tendency at different loads, the most common failure mechanism found was not contact welding, which would have been recorded as hard sticking by the life testing system. In fact, the most common failures were misses or high static contact resistance. Moreover, the only load at which sticking was predominant for any of the switches was Load 1, the least reactive load tested. Intuitively, we expected that sticking would have been more common with the heavier, more reactive loads, but this was not found to occur.

The RI-29 shows the best general performance across all loads. Its life degraded less than that of the other switches at higher loads, and no failures were recorded for the RI-29 on Load 7 before 100 million cycles.

We repeated the test on the RI-60 at Load 1, since the Weibull failure plot shows anomalous curvature indicating a different life characteristic to the other switches and loads. It appears that for this switch under Load 1 conditions, there is a “safe period” of about one million cycles during which no failures occur. After that period, failures due to high static contact resistance occur relatively rapidly. The repeat test showed the same characteristic.

For further information contact:

```
+-----+
| Stephen Day, Ph.D.      |
| VP, Engineering        |
| Coto Technology        |
| 55, Dupont Drive       |
| Providence, RI 02907   |
| Tel:      401-943-2686  |
| Fax:      401-942-0920  |
| E-mail:   sday@cotorelay.com |
+-----+
```

Reed\_Switch\_Life\_under\_Capacitive>Loading.doc