

# HOW TO REPLACE A 2-WIRE REED SWITCH WITH A 3-WIRE SENSOR

## Introduction

Two-wire control has advantages such as low cost, and easy expansion and installation. By serially connecting a resistor to a reed switch, the voltage drop across the resistor can be used as an input signal for the MCU to obtain on/off information. Conversely, solid-state sensors are typically three-terminal devices with power supply, ground and output pins. Also, solid-state sensors can carry only low current, typically less than 25mA. Therefore, one would need to implement an external MOSFET in order to convert a 3-wire circuit into a 2-wire circuit and provide higher carry-current capability.

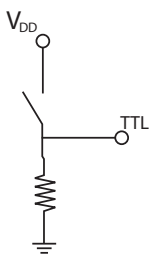

Figure-1: Application circuit of a two-wire reed switch

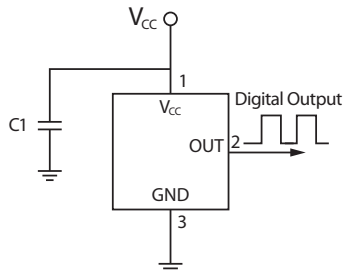

Figure-2: Application circuit of a three-wire solid state sensor

## Application Circuit

Reed switches are commonly referred to as Normally Closed (NC) or Normally Open (NO) types; this refers to the state of the switch when there is no magnetic field present. Figure 3 & 4 depict 3-to-2 wire conversion circuits which correspond to the NC & NO types of reed switch.

By utilizing the output voltage level of a RedRock TMR Magnetic Sensor RR121, we can control the conductance of MOSFET Q1. The voltage drop across resistor R1 will provide enough of a voltage difference to supply the RR121's operation. The voltage

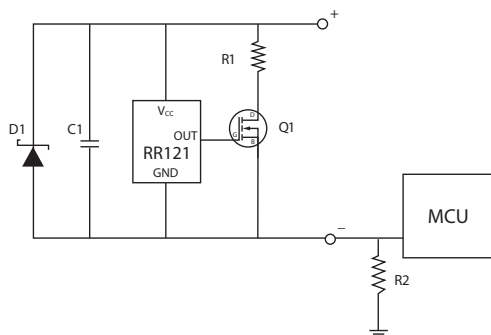

Figure-3: Application circuit for NC type sensor

drop across R2 is the input signal for the controller to read the state of the sensor. For an NC type of sensor circuit, (Fig.3) we chose an N-ch MOSFET where the conductance is determined by  $V_{gs}$ . If the magnetic field (B) is lower than the operating point ( $B_{op}$ ) of the RR121, the output voltage of RR121 will stay at a high level which makes  $V_{gs} > V_{th}$  of Q, at which time Q1 will be fully conducting.

On the other hand, if the magnetic field (B) is higher than the operating point ( $B_{op}$ ) of RR121, Q1 will not be conducting. The circuit current is determined by the resistance of R1 & R2. The input voltage level for the controller will be at a high level. The circuit current is contributed by the supply current of RR121 which is few micro ampere. The input voltage for the controller will be considered as a low level.

The mechanism for the NO type sensor is similar. However, instead of N-ch MOSFET, a P-ch MOSFET is used to initiate the opposite behavior with regard to the presence of a magnetic field. Unlike the NC type of sensor shown in Fig.3, if the magnetic field strength is lower than operating point of RR121, the P-ch MOSFET in Fig.4 won't conduct. As a result, the circuit current is as low as a few micro amperes.

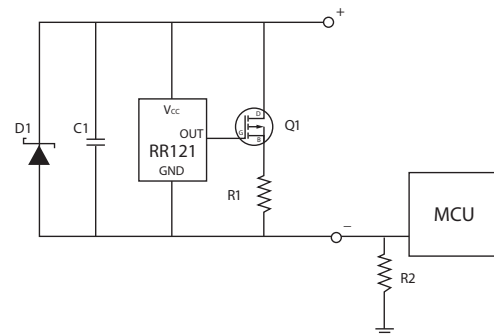

Figure-4: Application circuit for NO type sensor

## Conclusion

Two types of application circuits are shown to convert a three-wire RR121 sensor into a two-wire circuit. By using either N-ch or P-ch MOSFETs, we can provide either normally closed or normally open operation, depending on the requirement of the application.

For further application assistance, please contact Coto Technology's Sales and Applications Engineering team. ([appsupport@cotorelay.com](mailto:appsupport@cotorelay.com)).